

Douglas House, The Street, Beeston,  
King's Lynn, Norfolk. PE32 2NF  
Mobile: 07818 086650  
Email: [info@a2e-es.com](mailto:info@a2e-es.com)



**A2E Environmental Solutions Ltd**  
亞歐環保電機有限公司

### **A2E Environmental Solutions Ltd.**

We are happy to discuss a solution  
for your Industrial application

#### **Filtration:**

Paper Band Clarifier	Coolant Centrifuge
Magnetic Drum Filter	Hydrostatic Filter
Rotary Drum Filter	HydroCyclone Filter
Oil / Water Separators	Vacuum Filter
Filter Media	

#### **Swarf Processing & Handling:**

Steel Belting	Steel Belt Conveyors
Swarf Wringer	Swarf Shredder
Swarf Briquetting Press	

#### **Vehicles:**

Quad	ATV	Go-Kart	DuneBuggy
------	-----	---------	-----------

#### **Energy Savers:**

LED Bulbs	Wind Turbines	Solar Water Heating
-----------	---------------	---------------------

#### **Consultancy Services:**

Imports	Exports	Shipping/Freight
Engineering Services by		
Our man in China & with Your man in the UK		

**Web:** [www.a2e-es.com](http://www.a2e-es.com)

**Tel:** 07818 086650

A2E Environmental Solutions Ltd reserves the right to change specifications, equipment, materials, colour or any other item without notice. Please confirm full specification prior to purchase. Safety note: These machines could be hazardous if operated by unskilled workers: Always read, act & obey to the owners/maintenance manual. Always wear safety gear as necessary, ie. Helmet, boots, gloves etc when operating these machines.



**A2E Environmental Solutions Ltd**

Qual ity I mported Products, by  
Our man in China & Your man in the UK



## *Swarf Briquetter Model: BQ-*



*Heavy Duty, Simple & Robust Construction  
High Capacity, Quality Briquettes  
Suitable for Aluminium, Steel, Cast Iron*

[www.a2e-es.com](http://www.a2e-es.com)

# Swarf Briquetter

Model: BQ-

## Design

The Swarf Briquette Press is a heavy duty, robust, quality manufactured machine capable of producing high value, high density swarf briquettes from chips or: Steel, Aluminium, copper & Cast Iron. There is an inlet feed hopper & ram, Main Press cylinder, punch & die, Hydraulic oil pumping station & full PLC control system. All to European CE regulations.

## Function

The chipped material to be Briquetted is fed into the inlet hopper. The feed ram fills the swarf into the pressing chamber. Once filled the fast feed cylinder initially compresses followed by the main cylinder to create the high density briquette. The finished briquette is pushed out of the chamber into customers bin.

Options: Larger inlet hopper with Automatic feeding conveyor and output conveyors. Shredder unit prior to feeding so bushy swarf can be reduced to chips.

## Applications

Our Horizontal Briquetting Press is a cost effective choice for the small, medium & large company to create High value from your companies waste stream.

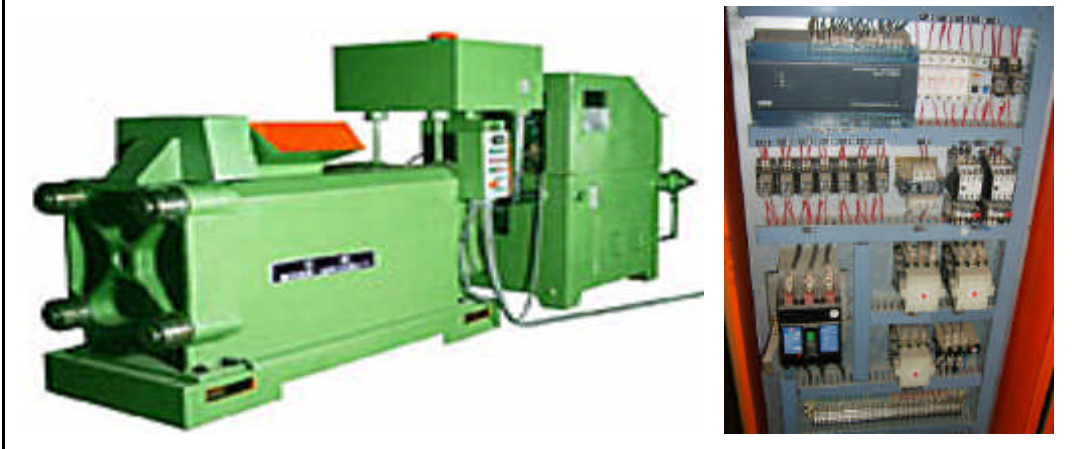
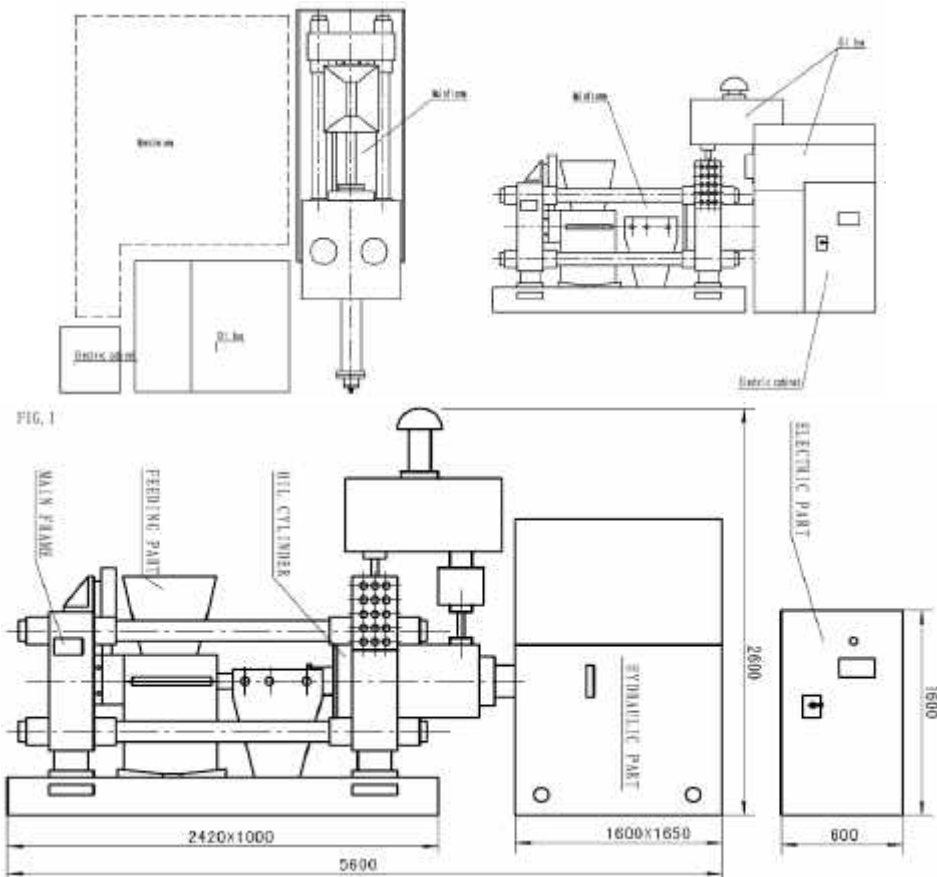

Model	Capacity ALUMINIUM (kg/hr)	Capacity STEEL (kg/hr)	Nominal Force (KN)	Dimensions (w x l x h) (Mtr)	Machine Weight (T)	Total Power (kW)
A2E - BQ 160	150 - 250	600 - 900	1600	4.1 x 1.1 x 1.5	5.0	24
A2E - BQ 230	300 - 400	1000 - 1500	2300	4.1 x 1.1 x 2.0	6.0	39
A2E - BQ 300	350 - 500	1200 - 1800	3000	5.5 x 1.6 x 2.6	7.5	47

Douglas House, The Street, Beeston,  
King's Lynn, Norfolk. PE32 2NF  
Mobile: 07818 086650  
Email: [info@a2e-es.com](mailto:info@a2e-es.com)



**A2E Environmental Solutions Ltd**

亞歐環保電機有限公司