

Douglas House, The Street, Beeston,  
King's Lynn, Norfolk. PE32 2NF  
Mobile: 07818 086650  
Email: [info@a2e-es.com](mailto:info@a2e-es.com)



**A2E Environmental Solutions Ltd**  
亞歐環保電機有限公司

### **A2E Environmental Solutions Ltd.**

We are happy to discuss a solution  
for your Industrial application

#### **Filtration:**

Paper Band Clarifier	Coolant Centrifuge
Magnetic Drum Filter	Hydrostatic Filter
Rotary Drum Filter	HydroCyclone Filter
Oil / Water Separators	Vacuum Filter
Filter Media	

#### **Swarf Processing & Handling:**

Steel Belting	Steel Belt Conveyors	Swarf Wringer
Swarf Shredder	Swarf Briquetting Press	

#### **Vehicles:**

Quad	ATV	Go-Kart	DuneBuggy
------	-----	---------	-----------

#### **Energy Savers:**

LED Bulbs	Wind Turbines	Solar Water Heating
-----------	---------------	---------------------

#### **Consultancy Services:**

Imports	Exports	Shipping/Freight
---------	---------	------------------

Engineering Services by  
Our man in China & with Your man in the UK

**Web: [www.a2e-es.com](http://www.a2e-es.com)**

**Tel: 07818 086650**

A2E Environmental Solutions Ltd reserves the right to change specifications, equipment, materials, colour or any other item without notice. Please confirm full specification prior to purchase. Safety note: These machines could be hazardous if operated by unskilled workers: Always read, act & obey to the owners/maintenance manual. Always wear safety gear as necessary, ie. Helmet, boots, gloves etc when operating these machines.



**A2E Environmental Solutions Ltd**  
Qual ity I mported Products, by  
Our man in China & Your man in the UK



## *Tramp Oil Separator Model: STOS-*

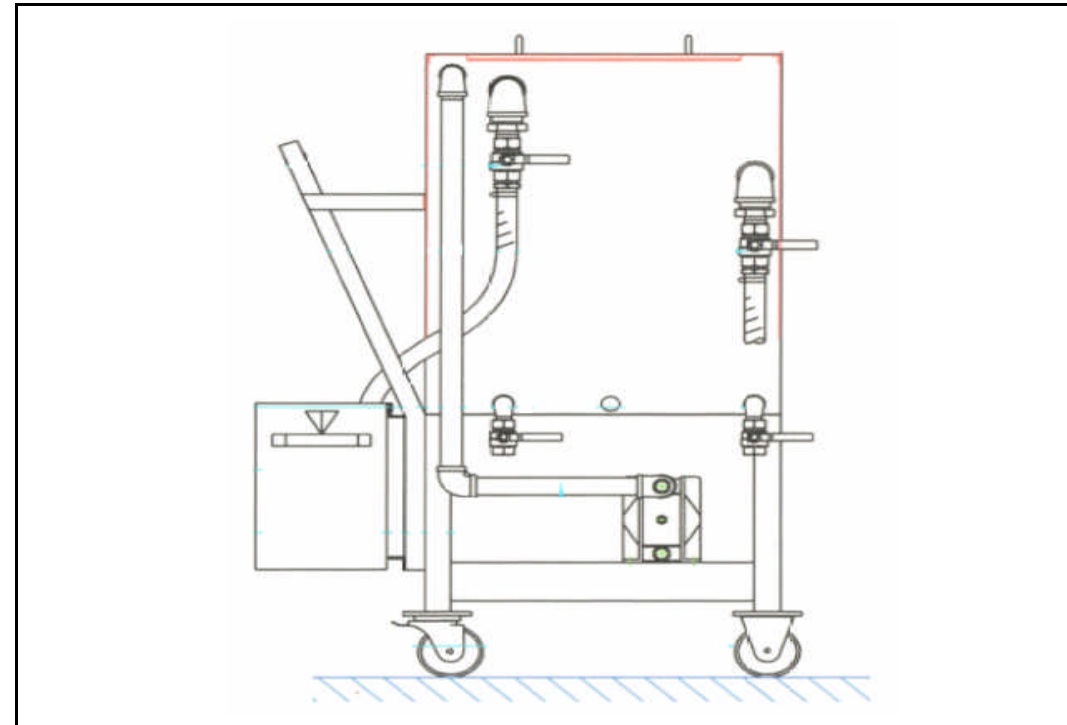

*Extends Coolant Life ~ Fully Automatic  
Waste Minimisation  
Prevents Odours & Bacteria levels*

**[www.a2e-es.com](http://www.a2e-es.com)**

# Tramp Oil Separator

Model: STOS-

## Design

The Tramp Oil Separator is a mobile coalescing unit in Mild Steel or Stainless Steel, complete with receiving tank & air pump. Simple design for free oil removal from water or soluble coolants to <math><15\text{mg/l}</math>.

Our STOS-250M with a maximum flow of 272 L/hr will handle machine or filter tanks up to 2000 Litres capacity.

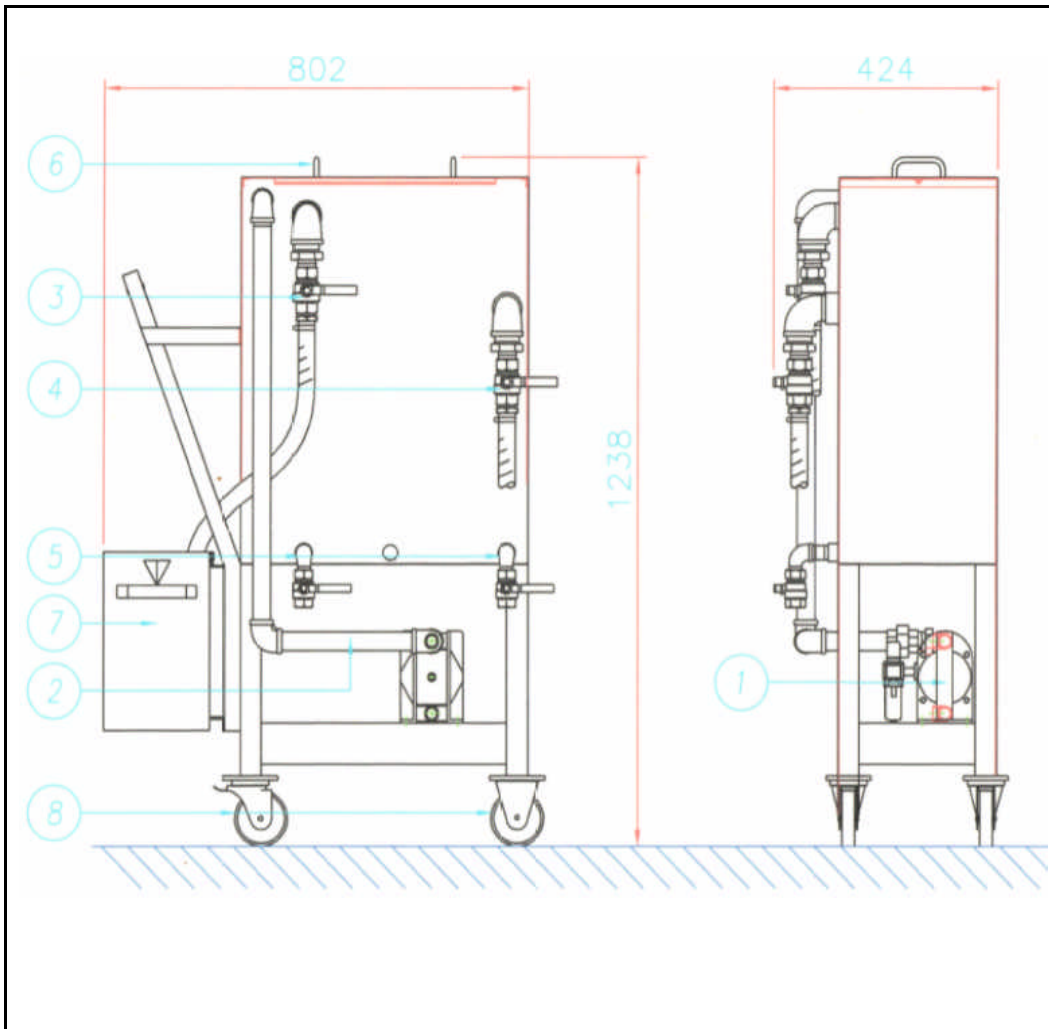

## Function

Dirty coolant is sucked from the surface of the required tank through the floating suction device & air pump. Within the primary section of the separator the initial free oils rise to the surface for removal. Semi dispersed free oils pass through into the coalescing media basket where the oil attracts to the oleophilic media rings & when the oil droplets increase they then rise to the surface for removal. The cleaned water or coolant flows down & back to the clean tank within the machine tool or tank.

Options: Mild Steel or Stainless Steel. Add a Bag Pre-Filter &/or Air sparge kit.

## Applications

Suitable for removal of tramp/free oil from: Coolant systems, Industrial waters, Factory machine sumps & effluent streams.

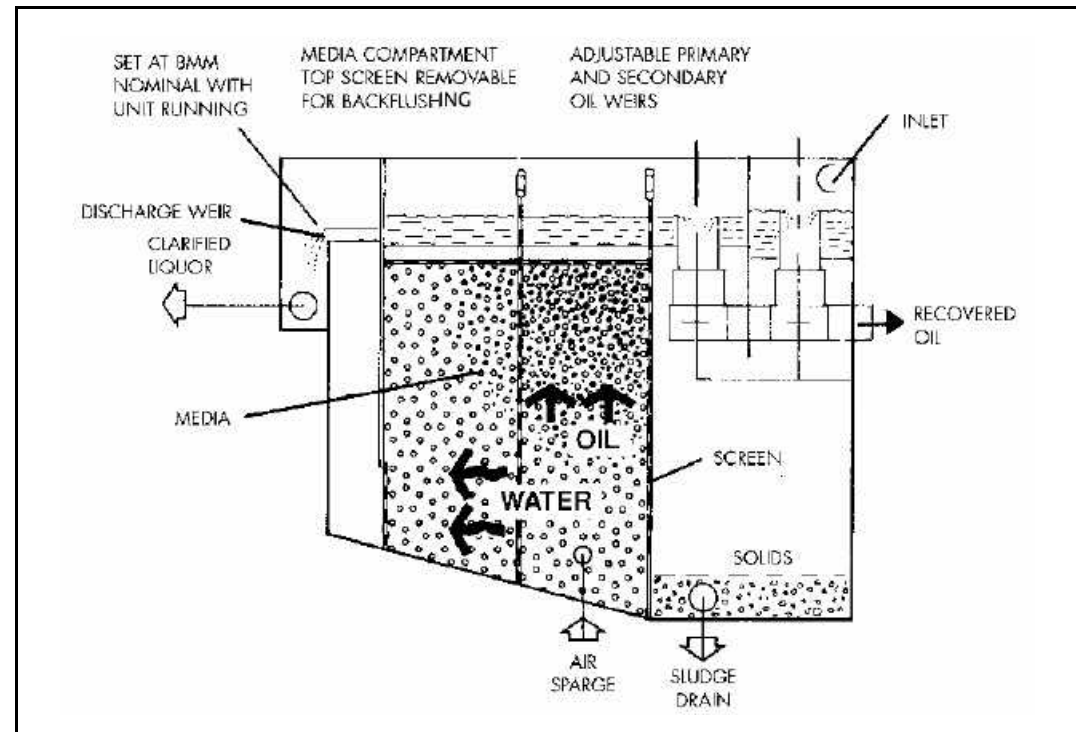

Douglas House, The Street, Beeston,  
King's Lynn, Norfolk. PE32 2NF  
Mobile: 07818 086650  
Email: [info@a2e-es.com](mailto:info@a2e-es.com)



**A2E Environmental Solutions Ltd**  
亞歐環保電機有限公司